

ROTARY VALVES

WHO WE ARE

TBMA specialises in the design and supply of components and (pneumatic) conveying systems for the processing of bulk solids goods.

Since our establishment in 1967, we have built up over 50 years of experience in the application of rotary drop-through and blow-through valves in the international process industry. Together with our knowledge of bulk material technology and process engineering, we can adequately advise you on the correct implementation and application of our rotary valves. Moreover, in our own test facility we can verify the proposed technical solution for your product in advance.

Our extensive range of high-quality equipment is suitable for conveying of powders and granules in the food, dairy, animal feed, chemical and mineral industries as well as for value-added logistics. From demanding hygienic to heavy industrial applications and from high end rotary valves to dust filter applications. We are also happy to use our expertise if you need a special application or an execution out of the ordinary.

Solutions beyond Bulk Handling

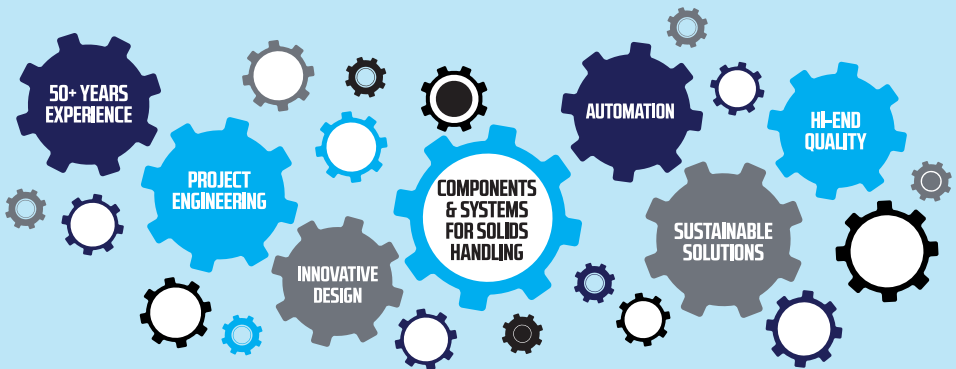

HIGH-DUTY ROTARY VALVES

TBMA high-duty drop-through and blow-through rotary valves are used for dosing powder and granular materials in 24/7 industrial processes. These valves are ATEX 2014/34/EU certified and can be used as a protective system up to 10 barg for products in dust class St1 and St2.

In hygienic production processes, it is of the utmost importance to prevent bacterial growth and product contamination and to guarantee traceability. At TBMA we work in accordance with the EHEDG, FDA and EC 1934/2005 guidelines, so that we can deliver solutions aimed at maximum product safety. This is crucial for both the consumer and the protection of your brand.

APPLICATIONS

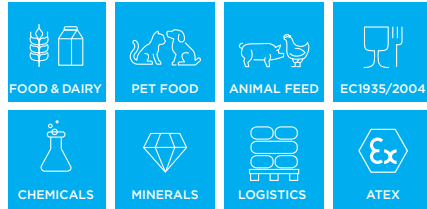

SPECIFICATIONS

HIGH DUTY ROTARY VALVES	H-AR	H-GR	SD*	DG**	H-AX
Flange sizes (DN)	150-500	150-350	150-500	175-350	150-350
Rotor volume (ltr/rev)	2,5-125	2,5-58	2,5-125	2,5-58	2,5-34
Differential pressure	1,5 barg	1,5 barg	1,5 barg	1,5 barg	1,5 barg
Standard design temperature	120 °C	120 °C	120 °C	120 °C	120 °C
Internal ATEX zone II 1/- D Ex h IIIC Da/-	yes	yes	yes	yes	yes
Flame proof	yes	yes	yes	yes	yes
Explosion proof	up to 10 barg	up to 10 barg	up to 10 barg	up to 10 barg	up to 2 barg

H-AR | H-GR: *Sanitary Design **Quickly-demountable with guiding bars

H-AR



The H-AR drop-through rotary valve has an optimally constructed inlet, which ensures a high filling degree and large capacity with minimal air leakage. In combination with a blow-through or venturi adapter, these valves are very suitable to absorb the differential pressure in pneumatic conveying systems.



SPECIFICATIONS

HIGH DUTY ROTARY VALVES	H-AR	H-GR	SD*	DG**	H-AX
Flange sizes (DN)	150-500	150-350	150-500	175-350	150-350
Rotor volume (l/rev)	2,5-125	2,5-58	2,5-125	2,5-58	2,5-34
Differential pressure	1,5 barg	1,5 barg	1,5 barg	1,5 barg	1,5 barg
Standard design temperature	120 °C	120 °C	120 °C	120 °C	120 °C
Internal ATEX zone II 1/- D Ex h IIIC Da/-	yes	yes	yes	yes	yes
Flame proof	yes	yes	yes	yes	yes
Explosion proof	up to 10 barg	up to 10 barg	up to 10 barg	up to 10 barg	up to 2 barg

H-AR | H-GR: *Sanitary Design **Quickly-demountable with guiding bars



H-AR with chain drive



H-AR with direct drive



H-AR with in-line drive

H-GR



TBMA high-duty H-GR blow-through rotary valves are equivalent to the H-AR valves and are used for direct dosing into pneumatic conveying systems in industrial applications.

The H-GR valves are equipped with connecting flanges for direct mounting into the pneumatic conveying line. The valves offer a suitable alternative with less building height compared to a drop-through valve with adapter. The integrated blow-through connections are adapted to the rotor shape, ensuring that the rotor pockets are completely blown empty. The valves are also standard provided with vent holes.



SPECIFICATIONS

HIGH DUTY ROTARY VALVES	H-AR	H-GR	SD*	DG**	H-AX
Flange sizes (DN)	150-500	150-350	150-500	175-350	150-350
Rotor volume (ltr/rev)	2,5-125	2,5-58	2,5-125	2,5-58	2,5-34
Differential pressure	1,5 barg	1,5 barg	1,5 barg	1,5 barg	1,5 barg
Standard design temperature	120 °C	120 °C	120 °C	120 °C	120 °C
Internal ATEX zone II 1/- D Ex h IIIC Da/-	yes	yes	yes	yes	yes
Flame proof	yes	yes	yes	yes	yes
Explosion proof	up to 10 barg	up to 10 barg	up to 10 barg	up to 10 barg	up to 2 barg

H-AR | H-GR: *Sanitary Design **Quickly-demountable with guiding bars



H-GR with chain drive



H-GR with direct drive



H-GR with in-line drive

Sanitary Design (SD)



SD sanitary rotary valves are suitable for hygienic applications in the food and dairy industry. The SD valves are available in drop-through (H-AR) and blow-through version (H-GR).

When designing our sanitary components, much attention is paid to the finishing. The rotors are equipped with fixed, chamfered blades and rounded pockets with a surface roughness of your choice. Body and covers are finished in the same way.

The SD valves are optionally available as Quick Clean (D) version or Quick Clean with guiding bars (DG), making them internally fully accessible as well as and easy and quickly cleanable.

SPECIFICATIONS

HIGH DUTY ROTARY VALVES	H-AR	H-GR	SD*	DG**	H-AX
Flange sizes (DN)	150-500	150-350	150-500	175-350	150-350
Rotor volume (ltr/rev)	2,5-125	2,5-58	2,5-125	2,5-58	2,5-34
Differential pressure	1,5 barg	1,5 barg	1,5 barg	1,5 barg	1,5 barg
Standard design temperature	120 °C	120 °C	120 °C	120 °C	120 °C
Internal ATEX zone II 1/- D Ex h IIIC Da/-	yes	yes	yes	yes	yes
Flame proof	yes	yes	yes	yes	yes
Explosion proof	up to 10 barg	up to 10 barg	up to 10 barg	up to 10 barg	up to 2 barg

H-AR | H-GR: *Sanitary Design **Quickly-demountable with guiding bars



H-ARSD with direct drive



H-GRSD with direct drive

Quick-Clean (DG)



DG Quick-Clean rotary valves are specially designed for processes where frequent cleaning and inspection are required. The DG valves are equipped with guiding bars and available in both drop-through (H-ARDG) as well as blow-through (H-GRDG) version.

Easy inspection and cleaning | Due to the double-bearing construction, the rotor can be easily and safely removed and manually turned in pulled-out position. This way it can be easily (wet) cleaned on all sides. The guiding bars are long enough to give the operator ample access for inspection and cleaning of the inside of the valve.

Self-centring shaft | The bearing construction guarantees a clearance-free run of the rotor and prevents damage when (dis)assembling. Contrary to valves of other brands, the TBMA Quick-Clean valves are equipped with a spline shaft. This means that after cleaning, the rotor can be quickly and easily mounted through the self-centring shaft. The rotor adjustment is fixed and needs no readjustment after (dis)assembly.

Minimal chance of damage | Because of the clearance-free suspension and fixed adjustment, any metal contact of the rotor is practically impossible. Moreover, the chance of damaging the rotor tips and/or the inside of the valve during (dis)assembly is limited to a minimum. This is particularly important for hygienic applications. In addition, the shaft seal cannot be damaged, because the shaft with spline remains in place when the rotor is pulled out.

SPECIFICATIONS



H-ARDG with direct drive



H-GRDG with direct drive

H-AX



H-AX drop-through rotary valves are equivalent to the H-AR valves and are used when the inlet size is more important than the rotor volume. The relatively large inlet ensures that even the most poorly flowing products are efficiently discharged.

These valves are equipped with a round and a square connecting flange. This allows the valve to be used as a transition piece from round to square or vice versa. This is favourable for the installation height and saves any mounting parts.



SPECIFICATIONS

HIGH DUTY ROTARY VALVES	H-AR	H-GR	SD*	DG**	H-AX
Flange sizes (DN)	150-500	150-350	150-500	175-350	150-350
Rotor volume (ltr/rev)	2,5-125	2,5-58	2,5-125	2,5-58	2,5-34
Differential pressure	1,5 barg	1,5 barg	1,5 bar	1,5 barg	1,5 barg
Standard design temperature	120 °C	120 °C	120 °C	120 °C	120 °C
Internal ATEX zone II 1/- D Ex h IIC Da/-	yes	yes	yes	yes	yes
Flame proof	yes	yes	yes	yes	yes
Explosion proof	up to 10 barg	up to 10 barg	up to 10 barg	up to 10 barg	up to 2 barg

H-AR | H-GR: *Sanitary Design **Quickly-dismountable with guiding bars



H-AX with chain drive



H-AX with direct drive



H-AX with in-line drive

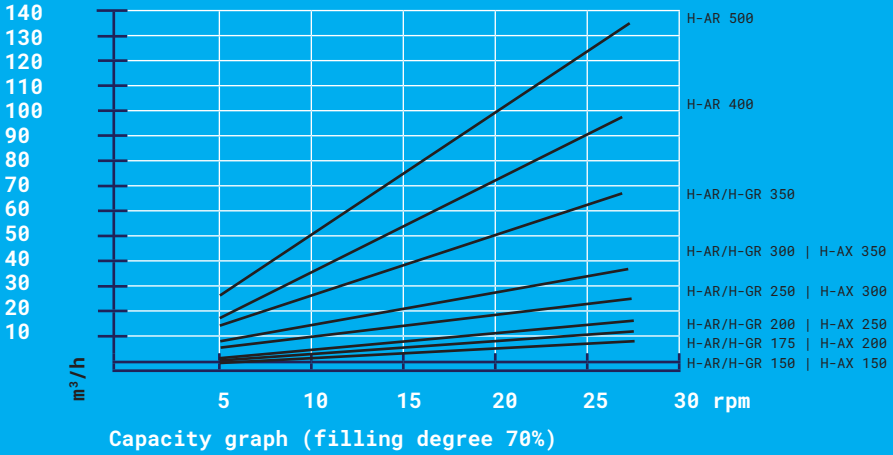

Executions	H-AR	H-GR	SD*	DG**	H-AX
Sanitary execution for the dairy and food industry	X	X	X	X	-
Quickly-demountable execution (D)	X	X	X	X	X
Quickly-demountable execution with guidance system (DG)	X	X	X	X	-
Corrosion resistant version for chemically aggressive products (3C/3N)	X	X	-	X	X
Abrasion resistant version for abrasive products (4C/4TCO)	X	X	-	X	X
Specially coated version for sticky products	X	X	X	X	X
High temperature version up to 600 °C	X	X	-	-	X
Customer-specific design	X	X	X	X	X
Options	H-AR	H-GR	SD*	DG**	H-AX
Electronic or mechanical flow measurement on air seal	X	X	X	X	X
Rotation detection	X	X	X	X	X
Deviating flange bores	X	X	X	X	X
Pulsating air injection system (for pocket release)	X	X	X	X	X
Ventilation bore on the body	X	X	X	X	X
Various inlet and vent adaptors	X	X	X	X	X
Various venturi and blow-through adaptors	X	-	X	X	X
Break pin or slip coupling	X	X	X	X	X
Drives	H-AR	H-GR	SD*	DG**	H-AX
Bare shaft	X	X	X	X	X
Geared motor with closed chain transmission	X	X	-	-	X
Hollow shaft direct drive	X	X	X	X	X
In-line drive with flexible coupling	X	X	X	-	X

H-AR | H-GR: *Sanitary Design **Quickly-demountable with guiding bars

Materials of construction	H-AR	H-GR	SD*	DG**	H-AX
Body and end covers					
Stainless steel AISI 316 / DIN 1.4408	X	X	X	X	-
Stainless steel AISI 316 / DIN 1.4408, hardened top layer	X	X	X	X	-
Cast iron GG25	X	X	-	X	X
Cast iron GG25, internally hard chromed	X	X	-	X	X
Cast iron GG25, internally anti-sticky coated	X	X	-	X	X
Cast iron GG25, completely chemically nickel-plated	X	X	-	X	X
Cast iron GG25, internally tungsten carbide coated	X	X	-	X	X
Steel S235JR (end cover non-drive side)	-	-	-	X	-
Rotor					
Fixed or adjustable blades	X	X	fixed	X	X
Stainless steel AISI 316 / DIN 1.4401	X	X	X	X	X
Stainless steel AISI 316 / DIN 1.4401 hardened top layer	X	X	X	X	X
Steel S235JR	X	X	-	X	X
Steel S235JR, shaft ends locally hard chromed	X	X	-	X	X
Steel S235JR, shaft ends tungsten carbide coated	X	X	-	X	X
Steel S235JR, non-sticky coated	X	X	-	X	X
Special executions: scalloped, reduced capacity, closed-end pockets	X	X	X	X	X
Rotor blades					
Stainless steel AISI 316 / DIN 1.4401, chamfered	X	X	X	X	X
Stainless steel AISI 316 / DIN 1.4401, hard chromed	X	X	X	X	X
Stainless steel AISI 316 / DIN 1.4401, hardened top layer	X	X	X	X	X
Steel S235JR, chamfered	X	X	-	X	X
Steel S235JR, hardened	X	X	-	X	X
Flexible blades (polyurethane, Vulkollan, Teflon, Viton, etc)	X	X	-	X	X
Hardox 400	X	X	-	X	X
Rotor bearing					
Outboard bearings, dust tight and sealed for life	X	X	X	X	X
Heat resistant bearings, suitable for product temperatures up to 600 °C	X	X	-	-	X
Shaft seals					
Gland packing, standard pre-pressed	X	X	-	X	X
Gland packing, food grade quality	X	X	X	X	X
Gland packing, for temperatures up to 600 °C	X	X	-	-	X
Gland packing, for abrasive products	X	X	X	-	X
Air purge	X	X	X	X	X

H-AR | H-GR: *Sanitary Design **Quickly-demountable with guiding bars

DUST AND CYCLONE VALVES



S-AX

TBMA S-AX dust valves are specially designed to be used under dust filters and cyclones. Applications with a differential pressure up to 500 mbarg where the valve primarily functions as an airlock or explosion barrier. The S-AX can be used as a protective system up to 2,5 barg for products in dust class St1 and St2. (optional)

These airlocks are made from GN40 nodular cast iron. This type of cast iron material is stronger than conventional cast iron: it is much less brittle making it more resistant to shock loads and has a high corrosion resistance. The installation weight of the S-AX is only 65 kg. The result is a particularly favourable price/quality ratio of this type of valves.

The S-AX valves are equipped with a round and a square connecting flange. This allows the valve to be used as a transition piece from round to square and vice versa.



APPLICATIONS



DUST AND CYCLONE VALVES	S-AX
Flange sizes (DN)	250 (round/ square)
Rotor volume (ltr/rev)	9,5
Differential pressure	0,5 barg
Standard design temperature	70 °C
Internal ATEX zone II 1/- D Ex h IIIC Da/-	yes
Flame proof	yes
Explosion proof	up to 2,5 barg

Executions

S-AX 250X

- Rotor with 8 polyurethane blades
- ATEX 2014/34/EU certified (optional)
- Direct drive with Helical-worm geared Nord or Euronorm motor reductor

S-AX 250X-1

Specifications as S-AX 250X extended with:

- Protective system up to 2,5 barg for products in dust class St1 and St2

Options**S-AX**

Rotation detection

X

Drives**S-AX**

Hollow shaft direct drive

X

Materials of construction**S-AX****Body and end covers**

GN40 cast iron

X

Rotor

Steel S235JR with 8 polyurethane blades

X

Rotor bearing

Bearing dust-tight and sealed for life (located in the end cover of the non-drive side; drive functions as counter bearing)

X

Shaft seals

NBR seals

X

EPDM seals

X

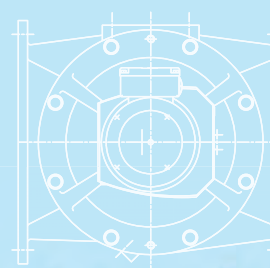
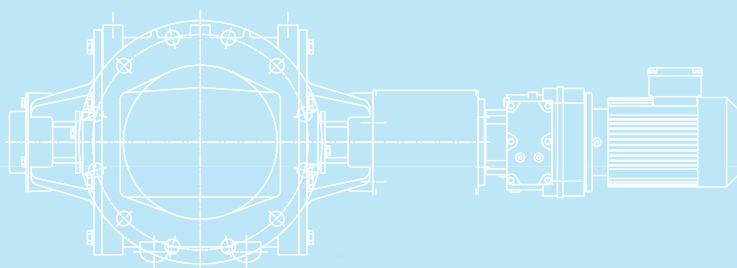

MEDIUM-DUTY ROTARY VALVES



The M-AX en R-AX drop-through valves are specially designed for standard applications with limited differential pressure. These valves are used for dosing of non-abrasive materials under cyclones or filters and in low-pressure pneumatic conveying systems.

M-AX

The M-AX valves are available in six sizes and are equipped with round connecting flanges.



R-AX

The R-AX are equipped with a round and a square connecting flange. This allows the valve to be used as a transition piece from round to square or vice versa. This is favourable for the installation height and saves any mounting parts. The R-AX valves are available in five sizes.



APPLICATIONS



MEDIUM DUTY ROTARY VALVES	M-AX	R-AX
Flange sizes (DN)	150-350	150-350
Rotor volume (ltr/rev)	2,5-58	2,5-34
Differential pressure	1 barg	1 barg
Standard design temperature	80 °C	80 °C
Internal ATEX zone II 1/- D Ex h IIIC Da/-	yes	yes
Flame proof	no	no
Explosion proof	no	no

Executions

M-AX / R-AX

Corrosion resistant version for chemically aggressive products (3C/3N)

X

Abrasion resistant version for abrasive products (4C/4TCO)

X

Options

M-AX / R-AX

Rotation detection

X

Ventilation bore on the body

X

Various inlet and vent adaptors

X

Various venturi and blow-through adaptors

X

Drives

M-AX / R-AX

Bare shaft

X

Hollow shaft direct drive

X

Materials of construction	M-AX / R-AX
Body and end covers	
Cast iron GG25	X
Cast iron GG25, internally hard chromed	X
Cast iron GG25, completely chemically nickel-plated	X
Cast iron GG25, internally tungsten carbide coated	X
Rotor	
Fixed or adjustable blades	X
Steel S235JR, shaft ends locally hard chromed	X
Steel S235JR, shaft ends tungsten carbide coated	X
Steel S235JR	X
Rotor blades	
Steel S235JR, chamfered	X
Steel S235JR, hardened	X
Flexible blades (polyurethane, Vulkollan, Teflon, Viton, etc)	X
Rotor bearing	
Closed bearings, dust-tight and sealed for life (located in the end cover of the non-drive side)	X
Shaft seals	
Air purge	X
NBR seals	X
EPDM seals	X

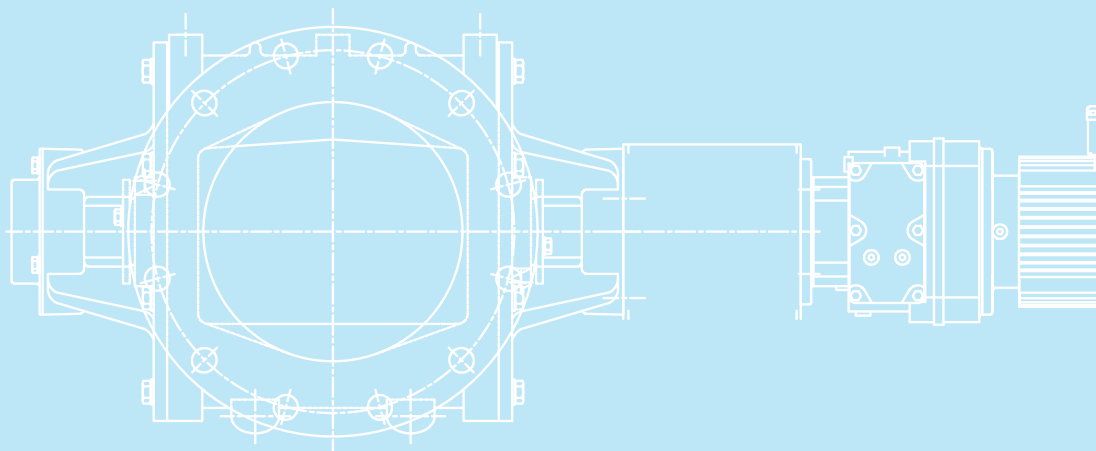

SPECIAL-DUTY ROTARY VALVES

In most cases, a smart choice of type and design will help you find the right rotary valve from our standard program. For special or highly critical applications, we will gladly use our experience and knowledge of systems and processes to find the right solution for your process.

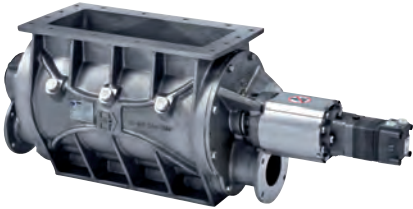

LINED CONTAINER TRANSPORT



GUARDED AIR LOCK SEAL



PED CERTIFIED



STEAM TRACING



INSPECTION HATCHES

ACCESSORIES

Air purge seals with differential pressure regulator

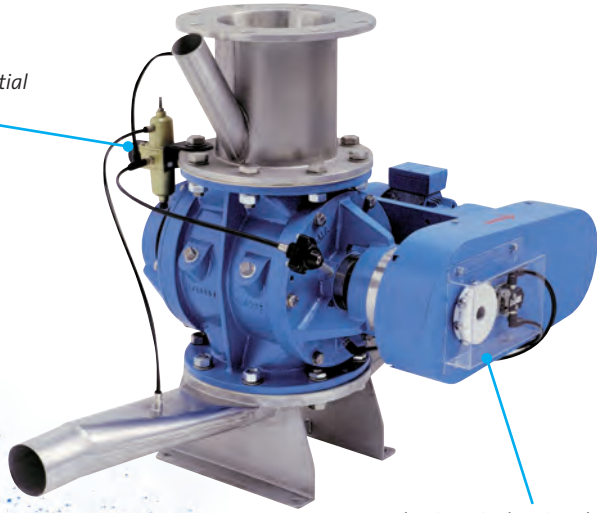

Pulsating air cleaning device

Inlet and vent adaptors

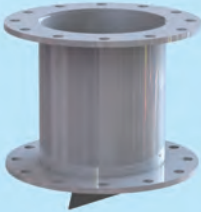

TYPE B



TYPE V

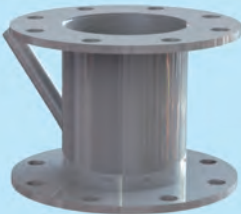

TYPE D

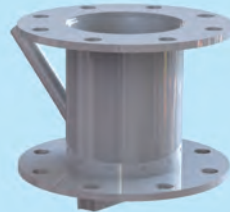

TYPE E

Outlet adaptors for pneumatic transport

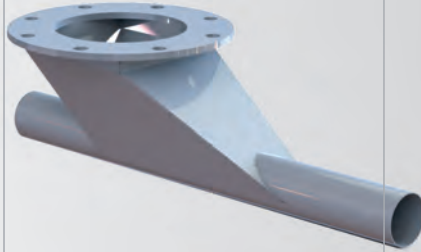

BLOW-THROUGH OUTLET ADAPTOR

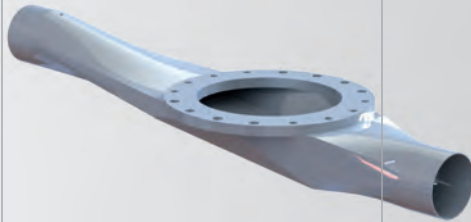

VENTURI | PIPE CONNECTIONS

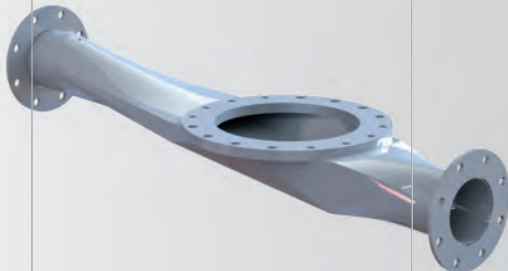

VENTURI | FLANGE CONNECTIONS

COMPONENTS

SYSTEMS

PROJECTS

TBMA Europe BV
Delfweg 18
NL-2211 VM Noordwijkerhout
The Netherlands

T +31 252 37 50 68
sales@tbma.com
www.tbma.com

TBMA België BV
Baron Van Loolaan 9
B-9940 Evergem
Belgium

T +32 9 236 64 69
sales@tbma.be
www.tbma.com