

Dimensions type HZK horizontal dosing valve with chain drive

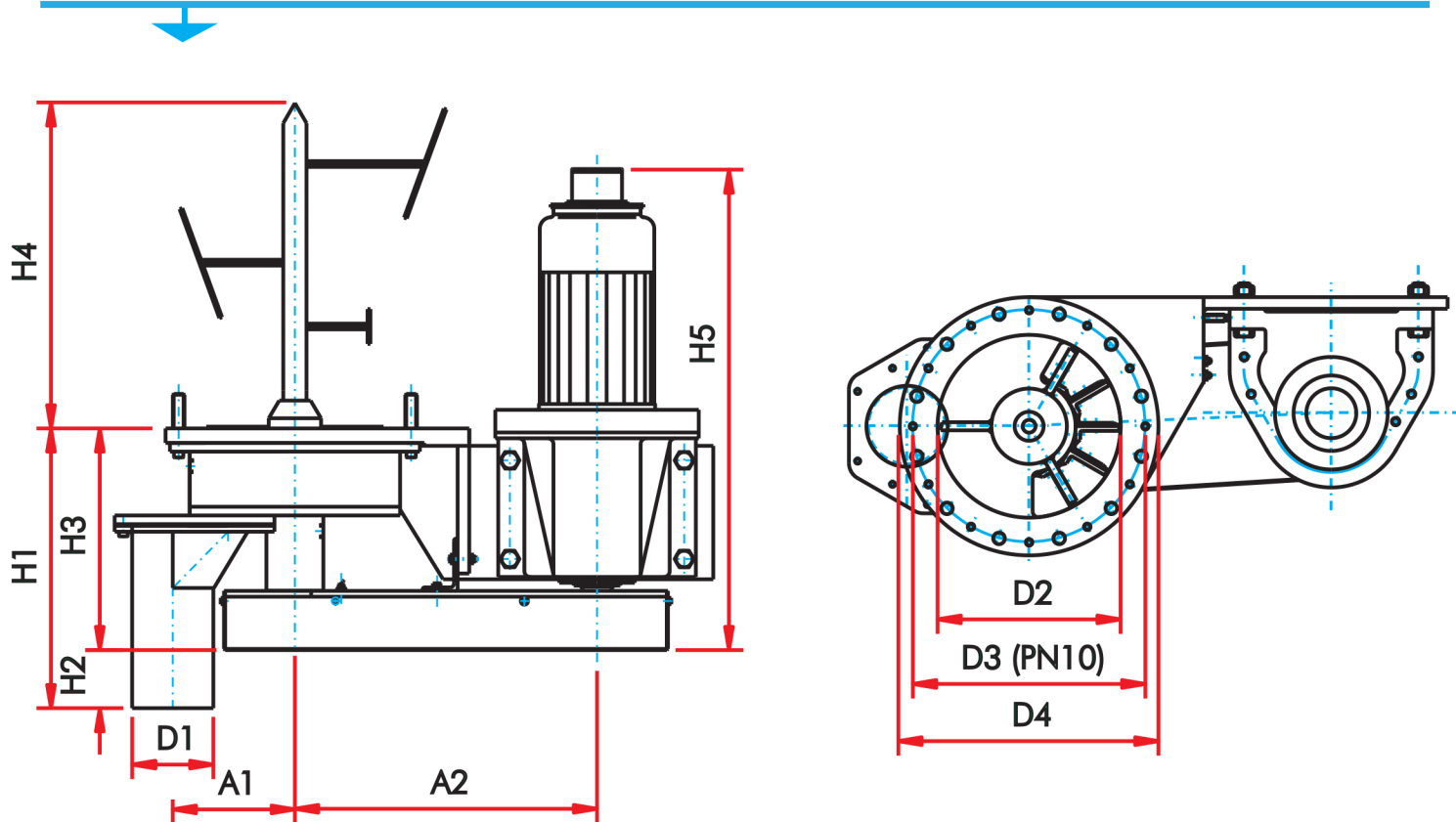

Size	Volume	A1	A2	D1	D2	D3	D4	H1	H2	H3	H4	H5	kg
150	0,5	120	260	60,3	155	240	285	400	100	300	250	540	77
200	1,4	150	350	76,1	215	295	340	425	100	325	400	550	115
300	4	220	465	88,9	310	400	445	480	100	380	480	580	210
400	9	285	594	114,3	395	515	565	670	110	560	520	820	460
500	18	285	870	168,3	495	620	670	700	110	590	580	860	565
600	35	360	900	219,1	595	725	780	800	120	680	700	950	850
700	60	420	950	273	695	840	895	900	120	780	800	1060	1060

Standard flange drilling: PN 10 (Alternative drilling patterns on request) All dimensions are in mm and might be subject to change (Design changes reserved)

