

Demontabele rotoruitvoering
Rotor release execution
Demontierbare Rotor Ausführung
Execution du rotor à démontage

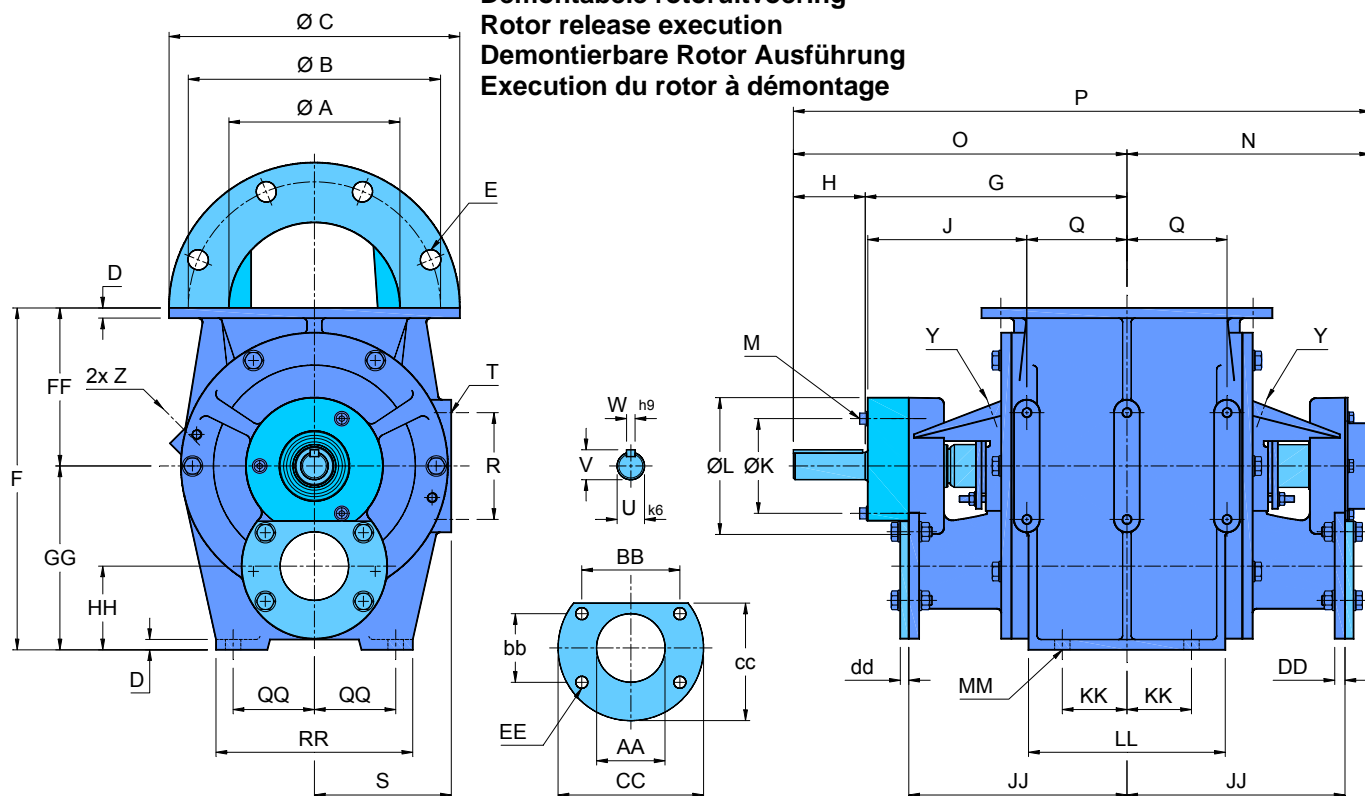

Type HGRD	Ltr. /rev.	A	B	C	D	E	F	G	H	J	K	L	M	N	O	P	Q	R	S	T	U
150	2,5	150	240	285	10	8x Ø23	280	246	63	173	95	120	M6	228	309	537	73	100	110	4xM10	30
175	5,5	175	270	315	12	8x Ø23	335	268	65	173	105	130	M6	250	333	583	95	100	130	6xM10	30
200	10,5	200	295	340	12	8x Ø23	400	305	87	186	128	160	M8	285	392	677	117	125	160	6xM12	32
250	19,0	250	350	395	14	12x Ø23	465	330	87	186	128	160	M8	310	417	727	142	125	190	6xM12	32
300	34,0	300	400	445	16	12x Ø23	555	379	89	198	170	205	M10	365	468	833	180	125	225	6xM12	38
350	58,0	350	460	505	21	16x Ø23	645	414	89	203	170	205	M10	400	503	903	210	125	270	6xM12	38

Type HGRD	V	W	AA	BB	bb	CC	cc	DD	dd	EE	FF	GG	HH	JJ	KK	LL	MM	QQ	RR	Y*	Z*	kg
150	33	8	50	95	-	120	95	10	10	2x Ø12	130	150	73	198	45	154	4x Ø12	67,5	160	¼"	½"	53
175	33	8	65	104	60	150	118	10	10	4x Ø12	160	175	79	220	65	190	4x Ø12	85	200	¼"	½"	71
200	35	10	80	115	80	170	137	12	10	4x Ø14	185	215	98	255	75	230	4x Ø18	95	230	¼"	¾"	118
250	35	10	100	139	98	200	163	12	10	4x Ø14	215	250	110	280	100	274	4x Ø18	120	275	¼"	¾"	155
300	41	10	125	164	115	230	189,5	14	15	4x Ø14	260	295	125	330	135	350	4x Ø22	125	320	¼"	1"	280
350	41	10	150	152	152	240	215	15	15	4x Ø14	305	340	130	365	155	410	4x Ø23	137,5	325	¼"	1¼"	410

PN10: Standaard flensboorpatroon – Standard drilling pattern - Standard Flanschanschluss- Plan de perçage standard
Afwijkende boorpatronen op aanvraag - Alternative flange drilling patterns on request
Andere Flanschanschlussmaße auf anfrage - Types spéciaux d'alésage de bride sur demande

*Note Y: Standaard afgeplugd – Standard plugged - Standard Endverschluss– Bouchon a colerette std

Ref.tek.: 17130-112

**Demontabele rotoruitvoering
Rotor release execution
Demontierbare Rotor Ausführung
Execution du rotor à démontage**

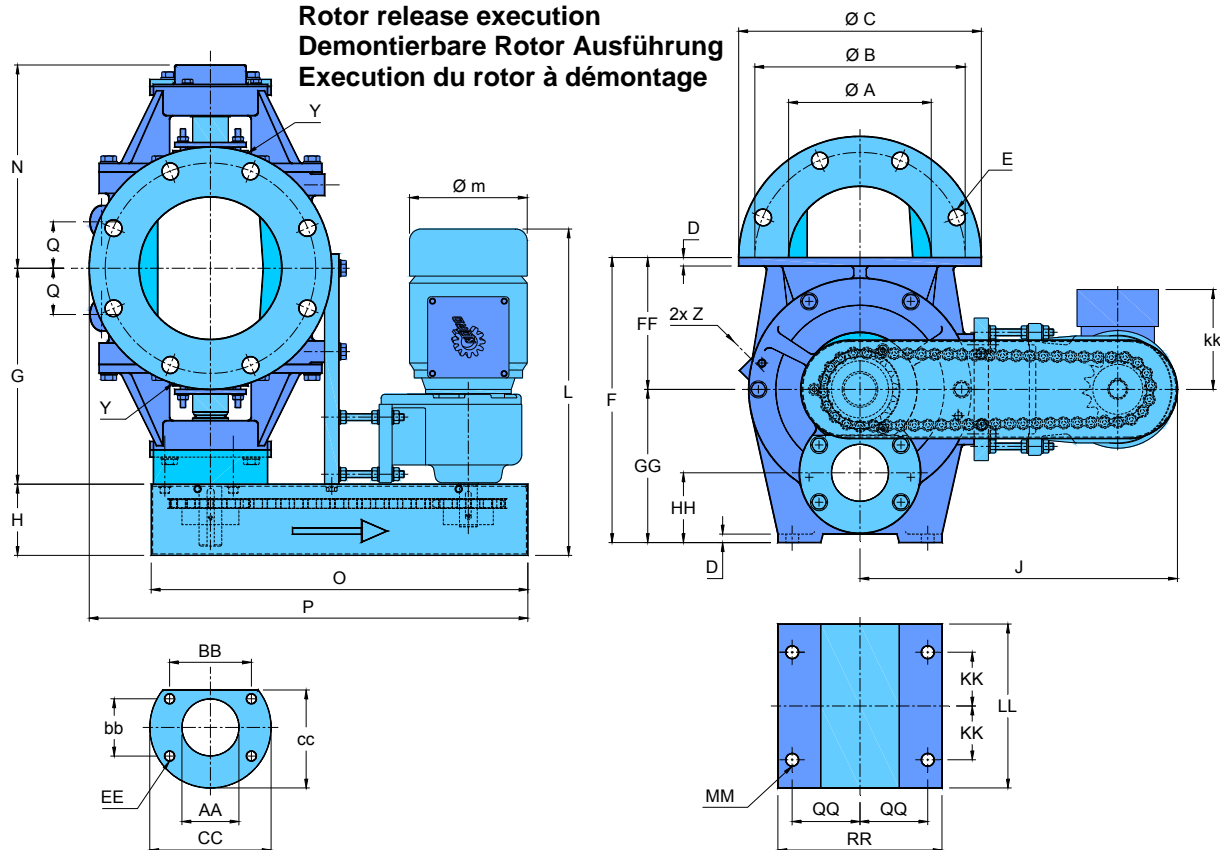

Standaard aandrijving / Standard drive / Standard Antrieb / Commande standard: Nord

Type H-GR	A	B	C	D	E	F	FF	G	GG	HH	N	AA	BB	bb	CC	cc	DD	dd	EE
150	150	240	285	10	8x Ø23	280	130	246	150	73	228	50	95	-	120	95	10	10	2x Ø12
175	175	270	315	12	8x Ø23	335	160	268	175	79	250	65	104	60	150	118	10	10	4x Ø12
200	200	295	340	12	8x Ø23	400	185	303	215	98	285	80	115	80	170	137	12	10	4x Ø14
250	250	350	395	14	12x Ø23	465	215	328	250	110	310	100	139	98	200	163	12	10	4x Ø14
300	300	400	445	16	12x Ø23	555	260	378	295	125	365	125	164	115	230	189,5	14	15	4x Ø14
350	350	460	505	21	16x Ø23	645	305	413	340	130	400	150	152	152	240	215	15	15	4x Ø14

Type H-GR	Ltr /rev	kW	Nm	kg	KK	LL	MM	QQ	RR	H	J	kk	L	m	O	P	Q	Y*	Z
150	2,5	0,37	131	75	45	154	4x Ø12	67,5	160	75	337	119	398	145	378	480	45	¼"	½"
175	5,5	0,37	131	93	65	190	4x Ø12	85	200	100	368	119	423	145	420	526	55	¼"	½"
200	10,5	0,75	286	165	75	230	4x Ø18	95	230	100	440	140	482	165	504	610	65	¼"	¾"
250	19,0	0,75	286	200	100	274	4x Ø18	120	275	100	480	140	482	165	554	678	75	¼"	¾"
300	34,0	1,5	478	350	135	350	4x Ø22	125	320	120	555	145	545	185	649	778	95	¼"	1"
350	58,0	1,5	478	490	155	410	4x Ø23	137,5	325	120	620	145	545	185	734	873	95	¼"	1¼"

IP 55 / ISO F: Beschermings/Isolatie klasse – Protection/Insulation class – Schutzart/Isolationsklasse - Protection/Isolation
230/400V-50Hz: Netspanning – Electrical supply – Betriebsspannung - Caractéristiques électriques

PN10: Standaard flensboorpatroon – Standard drilling pattern - Standard Flanschschluss- Plan de perçage standard
 Afwijkende boorpatronen op aanvraag - Alternative flange drilling patterns on request
 Andere Flanschschlussmaße auf anfrage - Types spéciaux d'alésage de bride sur demande

*Note Y: Standaard afgeplugd – Standard plugged - Standard Endverschluß– Bouchon a colerette std Ref.tek.: 17130-114